











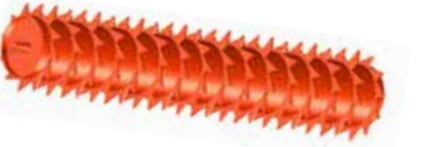

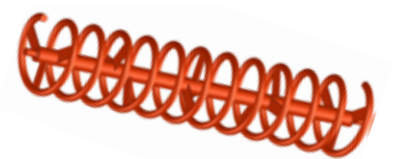









optional • optional • optionnel • Sonderausstattung • opcional

<ul style="list-style-type: none"> • marfnetto idraulico per regolazione dei rulli • hydraulic cylinder for roller adjustment • vérin hydraulique pour le réglage des rouleaux • Hydraulischer Zylinder für Walzenregulierung • gato hidráulico para la regulación de los rodillos 	<ul style="list-style-type: none"> • rullo liscio • smooth roller • rouleau lisse • Glatte Walze • rodillo liso 
<ul style="list-style-type: none"> • rullo a spuntoni, rullo a gabbia e rullo packer • spiked roller, cage roller, packer roller • rouleau à piques, rouleau à cage et rouleau packer • Zinkenwalze, Stabwalze, Packerwalze • rodillo con puntas, rodillo de jaula y rodillo packer 	<ul style="list-style-type: none"> • rullo a spuntoni • spicked roller • rouleau à piques • Zinkenwalze • rodillo con puntas 
<ul style="list-style-type: none"> • rullo packer • packer roller • rouleau packer • Packerwalze • rodillo packer 	<ul style="list-style-type: none"> • rullo a spirale • spiral roller • rouleau à spirale • spiral-Krümler • rodillo espiral 

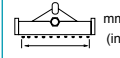
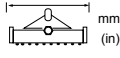
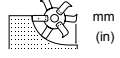

optional • optional • optionnel • Sonderausstattung • opcional

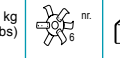
<ul style="list-style-type: none"> • zappa a squadra (per terreni sabbiosi) • square blades (for sandy soils) • houes à l'équerre (pour terrains sableux) • Winkelmesser 90° (für Sandboden) • azadas a escuadra (para terrenos arenosos) 	<ul style="list-style-type: none"> • rotore a lama con fissaggio a 3 bulloni • straight blades rotor with 3 fixing screws • rotor à lames avec 3 boulons de fixation • Rotor mit 1-Bolzen Befestigung Messern • rotor con cuchillas fijadas con 3 tornillos 
<ul style="list-style-type: none"> • rotore con zappe di estremità rivolte all'interno (versione Puglia) • Rotor with end blades turned inwards (Puglia version) • Rotor standard avec houes d'extrémité orientées à l'intérieur (version Puglia) • Rotor mit ausseren Messern nach Hinten (Puglia Modell) • rotor con azadas con las extremidades giradas hacia dentro (versión Puglia) 	<ul style="list-style-type: none"> • rotore a denti • toothed rotor • rotor denté • Gezählter Rotor • rotor con dientes 
<ul style="list-style-type: none"> • lama livellatrice • grading blade • lame niveleuse • Prallschiene • cuchilla niveladora 	<ul style="list-style-type: none"> • convogliatori laterali • side conveyors • convoyeurs latéraux • Seitenförderer • transportador lateral 
<ul style="list-style-type: none"> • coppia ruote laterali in ferro • pair of iron side wheels • couple de roues latérales en fer • paar von seitlichen Rädern aus Eisen • pareja de ruedas laterales 	<ul style="list-style-type: none"> • predisposizione per P.T.O. 1000 g/min • prédisposition pour P.T.O. 1000 t/min • predisposition for P.T.O. 1000 t/min • Ausstattung für Zapfwelle 1000 UMDR/Min • predisposición para P.T.O. 1000 rpm/min 
<ul style="list-style-type: none"> • Controflange • controflanges • contre-bridés • Gegenflansch • Contrabrida 	<ul style="list-style-type: none"> • zappe curve con trattamento Hille® • curve blades with Hille® treatment • houes courbes avec traitement Hille® • Bogenmesser Hille® • azadas curvas con tratamiento Hille® 
<ul style="list-style-type: none"> • coppia dischi convogliatori • conveying discs kit left - right • couple de roues latérales dx - sx • Leitscheiben lx u. rx • par de discos transportadores 	<ul style="list-style-type: none"> • coperchio con premicofani • spring-oaded cover • couvercle avec presse-capot • Deckel mit den drückend Haube • tapa con apreta-cafrev 

dati tecnici • technical data • fiches techniques • technische Daten • datos técnicos

MOD.	 hp	 mm (in)	 mm (in)	 mm (in)	 kg (lbs)	 kg (lbs)	 nr	 nr	 cat.
SPR 160	70 ▶ 90	1600 (63")	1710 (67")	100-200 (4-8")	560 (1234)	560 (1234)	36	36	2
SPR 185	70 ▶ 90	1800 (71")	1960 (77")	100-200 (4-8")	610 (1345)	610 (1345)	42	44	2
SPR 210	70 ▶ 90	2050 (81")	2210 (87")	100-200 (4-8")	660 (1455)	660 (1455)	48	52	2
SPR 235	70 ▶ 90	2300 (91")	2510 (97")	100-200 (4-8")	720 (1590)	720 (1590)	54	56	2
SPR 260	70 ▶ 90	2550 (100")	2760 (109")	100-200 (4-8")	770 (1697)	770 (1697)	60	64	2

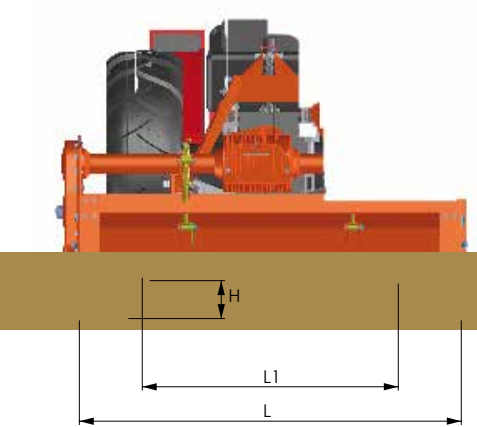
REAR FRAME

MOD.	L (mm)	L1 (mm)		H (mm)	
		MAX	MIN	MAX	MIN
SPR 160	1612	1372	1012	200	80
SPR 185	1862	1622	1262		
SPR 210	2112	1872	1512		



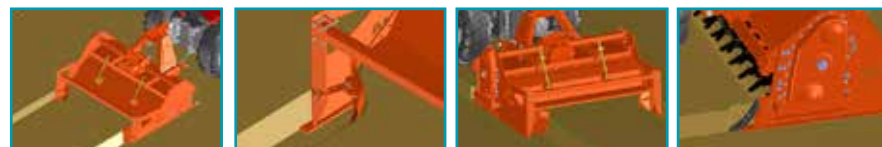





SICMA S.p.A.
C.da Cerreto, 39 - 66010 - Miglianico (Ch) - Italia
tel. +39 0871 95841 - fax +39 0871 950295
info@sicma.it - www.sicma.it

Rev. 02/2016



FRESATRICE • TILLER • FRAISE • BODENFRÄSE • FRESADORA

-  **Fissa molto pesante**
da 70 a 90 HP, a 4+2 velocità, PTO 540/1000 rpm
-  **Fixed, very heavy**
From 70 up to 90 HP, 4+2 speeds, PTO 540/1000 rpm
-  **Fixe, très lourde**
de 70 à 90 HP, 4+2 vitesses, PTO 540/1000 rpm
-  **Starr, sehr schwer**
von 70 bis 90 HP, 4+2-Gänge, PTO 540/1000 rpm
-  **Fija muy pesada**
de 70 a 90 HP, de 4 + 2 velocidades, PTO 540/1000 rpm





- attacchi 3° punto inferiore oscillanti
- lower 3rd point hitches with swinging movement
- attelages du 3ème point inférieur oscillantes
- untere III-Punktanschlüsse schwenkbar
- conexiones 3° punto inferior oscilantes



- Albero cardanico dimensione 8 con frizione parastrappi
- PTO shaft size 8 with flexible clutch
- Arbre prise de force série 8 avec embrayage
- Gelenkwelle Größe 8 mit Rutschkupplung
- Árbol cardán dimensión 8 con embrague de junta flexible



- telaio scatolato
- box frame
- cadre renforcé
- Doppelwanne
- bastidor en forma de caja



- Riduttore di fabbricazione SICMA, dotato di cuscinetti a rulli conici, a 4 (@540 rpm) + 2 (@1000 rpm) velocità con asta per il controllo del livello dell'olio
- 4-speeds (@540 rpm) + 2-speeds (@1000 rpm) gearbox made by SICMA with conical roller bearings and oil level indicator
- Réducteur de vitesse à 4 (@540 rpm) + 2 (@1000 rpm) rapports fabriqué par SICMA avec paliers à rouleaux coniques et jauge pour le contrôle du niveau de l'huile
- 4-Gang (@540 rpm) + 2-Gang (@1000 rpm) Schaltung hergestellt von SICMA mit konischen Wälzlagern und Stab für Ölcheck
- Reductor de fabricación SICMA, dotato de cojinetes de rodillos cónicos con 4 (@540 rpm) + 2 (@1000 rpm) velocidades y barra para el control del nivel de aceite

- Protezione antinfortunistica CE (di serie per la Comunità Europea)
- EC safety guards (standard in European Community)
- Protections CE (standard dans la Communauté Européenne)
- EG Schutzvorrichtung (Standard in der Europäischen Gemeinschaft)
- Protección CE para la prevención de accidentes (de serie para la Comunidad Europea)



- 6 zappe curve per flangia montate ad elica (per terreni normali)
- 6 curved blades per flange mounted in spiral line (for normal soils)
- 6 houes courbes par bride montées à hélice (pour terrains normaux)
- 6 Bogenmesser in Spiralform je Flansch (für Normalboden)
- 6 azadas curvas por brida, montadas en hélice (para terrenos normales)

- rotore standard (zappe di estremità rivolte verso l'esterno)
- standard rotor (with end blades turned outwards)
- rotor standard (avec houes d'extrémité orientées à l'extérieur)
- Standardrotor (mit Messern nach Außen)
- rotor estándar (azadas con las extremidades giradas hacia fuera)



- sistema di tenuta permanente "long life" nei cuscinetti supporto rotore
- "long life" seal provided inside the rotor's bearings
- système d'étanchéité permanent "long life" sur les paliers du rotor
- "Long life" lagerschutzsystem
- sistema de cierre permanente "long life" en los cojinetes de soporte del rotor

- piede di appoggio per stazionamento
- parking stand
- piéd de support
- Stützfuß
- pie de apoyo para estacionamiento

- Slitte laterali a norma CE, per la regolazione della profondità di lavoro
- Adjustable CE-compliant side skids, for the desired working depth
- Glissières latérales conformes aux normes CE, pour la réglage de la profondeur du travail
- Seitliche Kufen CE-konform, zur Arbeitstiefenregulierung
- Pafines laterales en conformidad CE, para regular la profundidad de trabajo

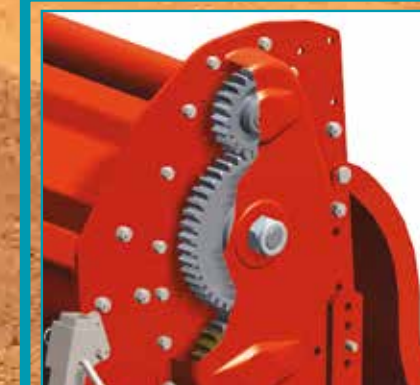

- Trasmissione laterale a ingranaggi in bagno d'olio e oblo per controllo livello
- Side gear drive in oil bath with sight glass for oil level control
- Transmission lateral par engrenages en bain d'huile et hublot de contrôle
- Seitengetriebe im Ölbad und Bullauge für Ölcheck
- Transmisión lateral con engranajes en baño de aceite y mirilla para control del nivel

- Verniciatura a polvere, che garantisce colore e brillantezza più durature
- Powder coating, ensuring more durable color and gloss
- Revêtement en poudre, qui assure couleur et brillance plus durable
- Pulverlackierung, die eine länger anhaltende Farbe und mehr Glanz garantiert
- Pintura en polvo, que garantiza un color y un brillo más duradero